



# REPORT OF PERFORMANCE

09-1250

**OBJECT** Toughened glass suspension insulator

**TYPE** ANSI Class 52-5

<b>Combined M&amp;E failing load</b>	<b>25000 (120) lbs (kN)</b>	<b>Nominal spacing</b>	<b>146 mm</b>
<b>Nominal diameter</b>	<b>255 mm</b>	<b>Nominal creepage distance</b>	<b>320 mm</b>

**MANUFACTURER** Nanjing Electric (Group) Co., Ltd.  
Jiangsu, China

**CLIENT** ProCable Energia e Telecomunicações Ltda.,  
São Paulo, Brazil  
(ordered by)  
Ru-Lena Ind. (Holding) Co., Ltd.  
Dalian, China

**REFERENCE** Contract no. 70870273-TDT-HVL 08-67929A

**TESTED BY** KEMA HIGH-VOLTAGE LABORATORY  
Arnhem, the Netherlands

**DATE OF TESTS** 8 December 2008 until 15 January 2009

**TEST PROGRAMME** Selected type tests as specified by the client (see page 2 and 3).

**SUMMARY AND CONCLUSION** The tests were passed.

This Report of Performance applies only to the object tested. The responsibility for conformity of any object having the same designations with that tested rests with the Manufacturer.

This report consists of 30 pages in total.

© Copyright: Only integral reproduction of this report is permitted without written permission from KEMA. Electronic copies in e.g. PDF-format or scanned version of this report may be available and have the status "for information only".  
The sealed and bound version of the report is the only valid version.

KEMA Nederland B.V.

  
P.G.A. Bus  
KEMA T&D Testing Services  
Managing Director

Arnhem, 1 April 2009

## TABLE OF CONTENTS

TABLE OF CONTENTS .....	2
1 Identification of the test object.....	4
1.1 Ratings assigned by the manufacturer .....	4
1.2 Description of the test object.....	4
1.3 List of drawings .....	4
2 General information.....	5
2.1 The tests were witnessed by.....	5
2.2 The tests were carried out by.....	5
2.3 Subcontracting .....	5
2.4 Purpose of the test .....	5
2.5 Measurement uncertainty.....	6
2.6 Applicable standards.....	6
3 Routine tests .....	7
3.1 Visual inspection .....	7
3.2 Mechanical test .....	7
4 Design tests.....	8
4.1 Low-frequency dry flashover test.....	8
4.2 Low-frequency wet flashover test.....	10
4.3 Critical impulse flashover tests.....	11
4.4 Radio-influence voltage test.....	12
4.5 Thermal-mechanical load cycle test.....	13
4.6 Thermal shock test.....	14
4.7 Residual-strength test .....	15
4.8 Impact test.....	16
4.9 Cotter key test .....	16
5 Sample tests.....	17
5.1 Verification of the dimensions .....	17
5.2 Verification of the displacements .....	18
5.3 Verification of the locking system.....	19
5.4 Galvanizing test.....	20
5.5 Thermal shock test.....	21
5.6 Mechanical failing load test.....	22
5.7 Puncture tests .....	23
6 Tests on locking device.....	24



6.1	Visual examination .....	24
6.2	Verification of the dimensions .....	25
6.3	Verification of the displacements .....	26
6.4	Verification of resistance to bending .....	27
APPENDIX A	MEASUREMENT UNCERTAINTIES.....	28
APPENDIX B	MANUFACTURER'S DRAWING/DATA SHEET .....	29

## 1 IDENTIFICATION OF THE TEST OBJECT

### 1.1 Ratings assigned by the manufacturer

Low-frequency dry flashover voltage	80	kV
Low-frequency wet flashover voltage	50	kV
Low-frequency wet withstand voltage	40	kV
Critical impulse flashover voltage, positive	125	kV
Critical impulse flashover voltage, negative	130	kV
Low-frequency puncture voltage	130	kV
Combined mechanical and electrical strength	25000 (120)	lbs (kN)
Shell diameter	255	mm
Unit spacing	146	mm
Leakage distance	320	mm

### 1.2 Description of the test object

Manufacturer	Nanjing Electric (Group) Co., Limited, Jiangsu, China
Type	U I210BSZ, ANSI Class 52-5
Connecting hardware coupling	Ball and Socket, Type J
Year of manufacture	2008
Marking of insulators	see manufacturer's drawing in appendix B

### 1.3 List of drawings

The manufacturer has guaranteed that the object submitted for tests has been manufactured in accordance with the following drawing.

KEMA has verified that this drawing adequately represent the object tested.

The following drawing is included in this Certificate.

Drawing number	Description	Date	Revision
-	insulator 52-5	approved 10/01/2008	-

## **2 GENERAL INFORMATION**

### **2.1 The tests were witnessed by**

<b>Name</b>	<b>Company</b>
Mr M. Coelho	ProCable, São Paulo, Brazil
Mr J.F. Dutra Mr J.M. Pinheiro	Eletrosul, Florianópolis, Brazil

### **2.2 The tests were carried out by**

<b>Name</b>	<b>Company</b>
Mr C.H. Beverwijk Mr G.J.A. Jansen Mr H.E. Keizer Mr A.P.M. Derksen Mr A.B.G.M. ten Have Mr R. Menger	KEMA Nederland B.V., Arnhem, the Netherlands

### **2.3 Subcontracting**

The following tests were subcontracted to KEMA TOS, Arnhem, the Netherlands:

- Galvanizing test

The following tests were subcontracted to MTSA, Arnhem, the Netherlands:

- Verification of the dimensions
- Verification of the displacements

The following tests were subcontracted to Bodycote materials testing, Emmen, the Netherlands:

- Hardness test

### **2.4 Purpose of the test**

Purpose of the test was to verify whether the material complies with the specified requirements.

## **2.5 Measurement uncertainty**

A table with measurement uncertainties is enclosed in appendix A. Unless otherwise indicated in the report, the measurement uncertainties of the results presented are as indicated in this table.

## **2.6 Applicable standards**

When reference is made to a standard and the date of issue is not stated, this applies to the latest issue, including amendments, which have been officially published prior to the date of the tests.

### 3 ROUTINE TESTS

#### 3.1 Visual inspection

##### Standard and date

Standard IEC 60383-1, clause 27  
Test dates 8 December 2008

##### Environmental conditions

Ambient temperature 15 °C  
Temperature of test object 15 °C

##### Requirements

The insulating parts shall have no surface defects prejudicial to satisfactory performance in service and there shall no bubbles in the glass greater than 5 mm in diameter.

##### Result

The test is passed.

#### 3.2 Mechanical test

##### Standard and date

Standard IEC 60383-1, clause 28  
Test dates 8 and 9 December 2008

##### Environmental conditions

Ambient temperature 15 °C  
Temperature of test object 15 °C

##### Characteristic test data

Tensile load 60 kN  
Duration  $\geq 3$  s

##### Requirements

No rejection of insulators.

##### Result

The test is passed.

## 4 DESIGN TESTS

### 4.1 Low-frequency dry flashover test

#### Standard and date

Standard ANSI C29.2-1992, clause 8.2.1

Test dates 10 and 11 December 2008

#### Environmental conditions (10 December 2008)

Ambient temperature	19,1 °C	Ambient air pressure	1008 hPa
Temperature of test object	19,1 °C	Humidity	5,6 g/m <sup>3</sup>

#### Environmental conditions (11 December 2008)

Ambient temperature	18,1 °C	Ambient air pressure	1006 hPa
Temperature of test object	18,1 °C	Humidity	5,8 g/m <sup>3</sup>

#### Correction factors ( $U_c = U \times K_{hc} / K_d$ ) (10 December 2008)

Air density,  $K_d$  1,016

Humidity,  $K_h$  1,125 (for  $U < 141$  kV :  $K_{hc} = 1 + (K_h - 1) \times U / 141$ )

#### Correction factors ( $U_c = U \times K_{hc} / K_d$ ) (11 December 2008)

Air density,  $K_d$  1,018

Humidity,  $K_h$  1,122 (for  $U < 141$  kV :  $K_{hc} = 1 + (K_h - 1) \times U / 141$ )

sample no.	measured flashover voltage U (kV)	corrected flashover voltage $U_c$ (kV)	average flashover voltage (kV)	minimum required flashover voltage (kV)
LFD-1 (11 Dec.)	79,3	83,3	87	
	80,1	84,2		
	83,1	87,5		
	86,0	90,8		
	85,1	89,6		
LFD-2 (11 Dec.)	73,5	76,8	78	
	73,2	76,5		
	72,9	76,2		
	78,8	82,7		
	74,9	78,4		
LFD-3 (10 Dec.)	71,8	75,1	76	
	72,2	75,6		
	81,2	85,7		
	72,2	75,6		
	86,0	91,1		
average			80	76

**Requirements**

The average dry flashover value of the three insulators shall be equal to or exceed 95% of the rated dry flashover value.

**Result**

The insulators passed the test.

## 4.2 Low-frequency wet flashover test

### Requirements and date

Standard ANSI C29.2-1992, clause 8.2.2  
 Test date 12 December 2008

### Environmental conditions

Ambient temperature 19,9 °C Ambient air pressure 1013 hPa  
 Temperature test object 19,9 °C Humidity 8,0 g/m<sup>3</sup>

### Characteristics of the artificial rain

Horizontal intensity 4,7 mm/min Resistivity at 20 °C 170 Ωm  
 Horizontal intensity 4,9 mm/min Angle of precipitation 45 °

### Correction factors ( $U_c = U/K_d$ )

Air density,  $K_d$  1,018

sample no.	measured flashover voltage U (kV)	corrected flashover voltage $U_c$ (kV)	average flashover voltage (kV)	minimum required flashover voltage (kV)
LDW-1	40,9	40,2	45	
	44,3	43,5		
	46,8	46,0		
	48,2	47,3		
	50,2	49,3		
LDW-2	43,9	43,1	45	
	50,1	49,2		
	44,0	43,2		
	48,2	47,3		
	47,1	46,3		
LDW-3	49,2	48,3	46	
	42,9	42,1		
	45,0	44,2		
	41,9	41,1		
	51,0	50,1		
average			45	45

### Requirements

The average wet flashover value of the three insulators shall be equal to or exceed 90% of the rated wet flashover value.

### Result

The insulators passed the test.

### 4.3 Critical impulse flashover tests

#### Requirements and date

Standard                   ANSI C29.2-1992, clause 8.2.3  
 Test date                   11 December 2008

#### Environmental conditions

Ambient temperature                   19,2 °C                                   Ambient air pressure                   1007 hPa  
 Temperature test object               19,2 °C                                   Humidity                                   6,0 g/m<sup>3</sup>

#### Correction factors ( $U_c = U \times K_{hc} / K_d$ )

Air density,  $K_d$                            1,015  
 Humidity,  $K_h$  (positive)               1,092 (for  $U < 141$  kV :  $K_{hc} = 1 + (K_h - 1) \times U / 141$ )  
 Humidity,  $K_h$  (negative)               1,079 (for  $U < 141$  kV :  $K_{hc} = 1 + (K_h - 1) \times U / 141$ )

sample no.	polarity	number of applied impulses	measured average flashover voltage U (kV)	corrected average flashover voltage $U_c$ (kV)	minimum required flashover voltage (kV)
CI-1	positive	27	116,9	124,0	
CI-2	positive	28	114,8	121,6	
CI-3	positive	27	116,9	124,0	
average				123,2	115,0
CI-1	negative	27	123,1	129,6	
CI-2	negative	27	120,4	126,6	
CI-3	negative	27	120,2	126,4	
average				127,5	119,6

#### Requirements

The average critical impulse flashover value of the three insulators shall be equal to or exceed 92% of the rated critical impulse flashover value.

#### Result

The insulators passed the test.

#### 4.4 Radio-influence voltage test

##### Requirements and date

Standard ANSI C29.2-1992, clause 8.2.4  
Test date 10 December 2008

##### Environmental conditions

Ambient temperature 18 °C Ambient air pressure 1008 hPa  
Temperature test object 18 °C Humidity 5,2 g/m<sup>3</sup>

##### Test conditions

Applied voltage 10 kV  
Frequency 60 Hz

sample no.	measured background noise (μV)	measured RIV (μV)
LFD-1	1,8	≤ 1,8
LFD-2	1,8	6,3
LFD-3	1,8	≤ 1,8

##### Requirements

The maximum RIV at 1000 kHz shall not exceed 50 μV.

##### Result

The insulators passed the test.

#### 4.5 Thermal-mechanical load cycle test

##### Requirements and date

Standard                      ANSI C29.2-1992, clause 8.2.5  
 Test dates                    8-12 December 2008

##### Test conditions (for thermal-mechanical load cycles)

No. of 24h-cycles	4	Tensile load	72 kN
Cooling temperature	-30 °C	Heating temperature	+40 °C
Cooling period	> 4 h	Heating period	> 4 h

Results of the combined mechanical and electrical-strength test			
sample no.	combined mechanical and electrical failing load (kN)	glass broken before ultimate mechanical fracture	fracture pattern
TML-1	169	no	cement
TML-2	171	no	cap
TML-3	174	no	cement
TML-4	170	no	cap
TML-5	169	no	cap
TML-6	168	no	cap
TML-7	170	no	cap
TML-8	168	no	cap
TML-9	169	no	cement
TML-10	170	no	cap

Average value	$\bar{X}$	169,8 kN
Lower limit of the average value	$\bar{X}_L = SFL + 1,2\bar{S}$	122,1 kN
Standard deviation	S	1,75 kN
Average standard deviation	$\bar{S} = S$	1,75 kN
	$1,72\bar{S}$	3,0 kN
Combined mechanical and electrical strength	SFL	120 kN

##### Requirements

$$\bar{X} \geq \bar{X}_L \text{ and } S \leq 1,72\bar{S}$$

##### Result

The insulators passed the test.

#### 4.6 Thermal shock test

##### Requirements and date

Standard ANSI C29.2-1992, clause 8.2.6

Test date 11 December 2008

sample no's.	temperatures of the hot and cold water baths		time of submersion in each water bath	total no. of cycles
	hot (°C)	cold (°C)	(min)	
TS-1 ... TS-5	96 ± 2	4 ± 2	10	10

##### Requirements

Failure of any of the five insulators shall not occur.

##### Result

The insulators passed the test.

#### 4.7 Residual-strength test

##### Requirements and date

Standard ANSI C29.2-1992, clause 8.2.7

Test date 9 December 2008

sample no.	mechanical failing load (kN)	fracture pattern
RS-1	109	cement
RS-2	107	cement
RS-3	126	cement
RS-4	117	cement
RS-5	128	cement
RS-6	121	cement
RS-7	130	cement
RS-8	117	cement
RS-9	117	cement
RS-10	122	cement
RS-11	121	cement
RS-12	117	cement
RS-13	120	cement

sample no.	mechanical failing load (kN)	fracture pattern
RS-14	120	cement
RS-15	106	cement
RS-16	118	cement
RS-17	125	cement
RS-18	114	cement
RS-19	131	cement
RS-20	123	cement
RS-21	109	cement
RS-22	133	cement
RS-23	118	cement
RS-24	125	cement
RS-25	128	cement

Average value	$\bar{X}_R$	120,1	kN
Standard deviation	$S_R$	7,38	kN
Tension proof load	TPL	55,5	kN
	$(1,2 \times TPL) + 1,645S_R$	78,7	kN

##### Requirements

$$\bar{X}_R \geq (1,2 \times TPL) + 1,645S_R$$

##### Result

The insulators passed the test.

#### 4.8 Impact test

##### Requirements and date

Standard ANSI C29.2-1992, clause 8.2.8  
 Test date 10 December 2008

sample no.	tensile load applied during impact test (N)	applied impact (Nm)
CI-1	8896	7
CI-2	8896	7
CI-3	8896	7

##### Requirements

Failure of any of the three insulators shall not occur.

##### Result

The insulators passed the test.

#### 4.9 Cotter key test

##### Requirements and date

Standard ANSI C29.2-1992, clause 8.2.9  
 Test date 9 December 2008

sample no.	1 <sup>st</sup> disengagement force (N)	2 <sup>nd</sup> disengagement force (N)	3 <sup>rd</sup> disengagement force (N)
QC-1	163	155	129
QC-3	185	153	156
QC-4	187	174	163

##### Requirements

The disengagement force shall be between 111 N and 667 N.

##### Result

The insulators passed the test.

## 5 SAMPLE TESTS

### 5.1 Verification of the dimensions

#### Standard and date

Standard IEC 60383-1, clause 17  
 Test dates 10 till 12 December 2008

#### Specifications

Shell diameter  $255 \pm 11$  mm  
 Unit spacing  $146 \pm 4,6$  mm  
 Leakage distance  $320 \pm 14$  mm  
 Coupling size type J (ball and socket)

sample no.	gauging	shell diameter (min – max) (mm)	unit spacing (mm)	leakage distance (mm)
E1-1	OK	255,47 – 255,62	143,65	330
E1-2	OK	254,00 – 254,77	142,37	324
E1-3	OK	254,95 – 255,15	142,90	328
E1-4	OK	255,10 – 255,20	142,83	325
E1-5	OK	255,04 – 255,07	143,99	331
E1-6	OK	254,00 – 254,50	142,49	324
E1-7	OK	254,79 – 255,43	142,74	331
E1-8	OK	255,32 – 255,75	143,54	325
E1-9	OK	254,80 – 255,40	142,96	327
E1-10	OK	254,80 – 255,39	143,03	324
E1-11	OK	254,00 – 254,67	141,94	327
E1-12	OK	254,86 – 255,40	142,83	329
E2-1	OK	254,90 – 255,10	142,97	325
E2-2	OK	254,90 – 255,10	142,84	324
E2-3	OK	255,35 – 255,66	143,44	324
E2-4	OK	254,80 – 255,10	143,75	326
E2-5	OK	254,50 – 254,50	143,42	325
E2-6	OK	254,90 – 255,90	143,49	324

#### Requirements

Conformity with the dimensions and its tolerances as given in the manufacturer's drawing.

#### Result

The insulators passed the test.

## 5.2 Verification of the displacements

### Standard and date

Standard IEC 60383-1, clause 21  
 Test dates 10 and 11 December 2008

### Specifications

Shell diameter 255 mm

sample no.	axial displacement (mm)	radial displacement (mm)
E1-1	4,86	1,16
E1-2	1,72	2,01
E1-3	4,02	1,65
E1-4	7,76	1,75
E1-5	4,12	1,18
E1-6	1,54	1,89
E1-7	3,57	1,59
E1-8	2,94	1,84
E1-9	1,84	0,71
E1-10	2,56	2,22
E1-11	5,32	1,37
E1-12	5,34	2,06
E2-1	2,28	3,04
E2-2	4,90	2,05
E2-3	5,66	2,83
E2-4	3,30	0,95
E2-5	3,16	1,96
E2-6	6,59	1,90

### Requirements

Variation on axial displacement: 4% of the nominal insulator diameter.  
 Variation on radial displacement: 3% of the nominal insulator diameter.

### Result

The insulators passed the test.

### 5.3 Verification of the locking system

**Standard and date**

Standard IEC 60383-1, clause 22

Test dates 12 December 2008

sample no.	1 <sup>st</sup> disengagement force (N)	2 <sup>nd</sup> disengagement force (N)	3 <sup>rd</sup> disengagement force (N)
E1-1	174	131	178
E1-2	188	135	137
E1-3	133	175	155
E1-4	135	160	195
E1-5	174	159	136
E1-6	179	190	140
E1-7	143	170	141
E1-8	141	125	153
E1-9	159	158	158
E1-10	186	166	165
E1-11	195	185	183
E1-12	128	185	197
E2-1	154	144	189
E2-2	134	137	169
E2-3	172	183	157
E2-4	183	187	145
E2-5	155	197	142
E2-6	199	198	172

**Requirements**

Conformity of the locking device with the requirements of IEC 60372 (see paragraph 6).

No uncoupling shall occur during the verification of locking.

The locking position for the legs shall not protrude beyond the entry of the socket and a tool shall be introduced into the eye, to pull the split-pin from the locking position to the coupling position.

The disengagement force shall be between 50 N and 500 N.

**Result**

The insulators passed the test.

## 5.4 Galvanizing test

### Requirements and date

Standard IEC 60383-1, clause 26

Test dates 16 December 2008

sample no.	lowest zinc layer thickness (µm)	highest zinc layer thickness (µm)	average zinc layer thickness of individual specimen (µm)	average of entire sample (µm)
E2-1	85	234	138,4	131,2
E2-2	82	180	123,0	
E2-3	80	152	108,1	
E2-4	89	225	135,4	
E2-5	95	257	176,6	
E2-6	85	139	105,7	

### Requirements

Average zinc layer thickness of individual specimen:  $\geq 500 \text{ g/m}^2$  (= 70 µm)

Average zinc layer thickness of entire sample:  $\geq 600 \text{ g/m}^2$  (= 85 µm)

### Result

The insulators passed the test.

## 5.5 Thermal shock test

### Requirements and date

Standard IEC 60383-1, clause 24  
Test date 17 December 2008

sample no's.	temperature of hot oven (°C)	temperature of water bath (°C)
E2-1 ... E2-6	133	7

### Requirements

Failure of any of the five insulators shall not occur.

### Result

The insulators passed the test.

## 5.6 Mechanical failing load test

### Requirements and date

Standard IEC 60383-1, clause 19  
 Test dates 16 December 2008

sample no.	mechanical failing load (kN)	fracture pattern
E1-1	170	pin
E1-2	169	cement
E1-3	173	pin
E1-4	172	cement
E1-5	174	cement
E1-6	173	cement
E1-7	172	pin
E1-8	173	pin
E1-9	172	pin
E1-10	168	cement
E1-11	170	cement
E1-12	172	pin

Average value	$\bar{X}$	171,5	kN
Lower limit of the average value	$\bar{X}_L = SFL + 1,7S$	132,0	kN
Standard deviation	S	1,83	kN
Mechanical failing load	SFL	120	kN

### Requirements

$$\bar{X} \geq \bar{X}_L$$

### Result

The insulators passed the test.

## 5.7 Puncture tests

### Requirements and date

Standard IEC 60383-1, clause 15

Test dates 16 December 2008

sample no.	specified and applied puncture voltage (kV)	puncture below specified puncture voltage	measured puncture voltage <sup>1)</sup> (kV)
E2-2	130	no	175
E2-3	130	no	175
E2-4	130	no	180
E2-5	130	no	165
E2-6	130	no	170
E2-7	130	no	170

1) for information only

### Requirements

No puncture shall occur below the specified puncture voltage.

### Result

The insulators passed the test.

## 6 TESTS ON LOCKING DEVICE

### 6.1 Visual examination

#### Standard and date

Standard IEC 60372, clause 12.1

Test dates 15 January 2009

sample no's	surface cracking or incipient cracks (AQL = 1,5%)	rough surface or blisters (AQL = 6,5%)	other defects
50	none	none	none

#### Remark

AQL = Acceptable Quality Level.

#### Requirements

The locking device shall not have any defects according to table I of IEC 60372.

#### Result

The locking device passed the test.

## 6.2 Verification of the dimensions

### Standard and date

Standard IEC 60372, clause 12.1

Test dates 18 December 2008

sample no's.	S (mm)	T (mm)	$F_{2 \text{ min}}$ (mm)	$R_{\text{min}}$ (mm)	$L_{\text{min}}$ (mm)
1	3,22	5,62	10,52	4,51	38,25
2	3,22	5,61	10,47	4,25	39,05
3	3,21	5,60	10,54	4,43	38,55
4	3,22	5,54	10,61	4,40	38,75
5	3,22	5,58	10,63	4,45	39,00
requirement	$3,2 \pm 0,1$	$5,5^{+0,2}_0$	$> 10,3$	$> 3,0$	$> 38,0$

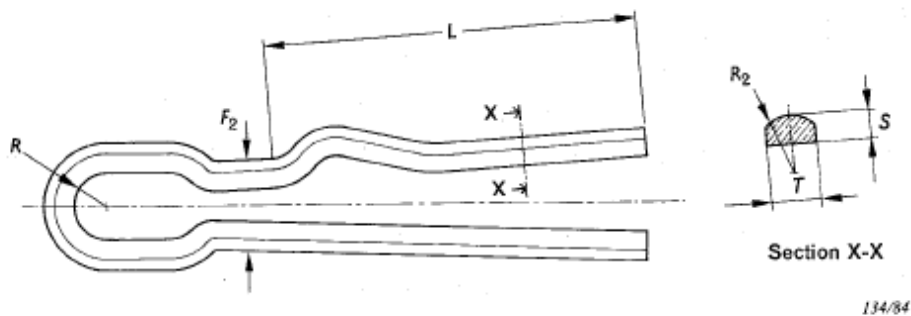

134/84

### Requirements

Conformity with the dimensions and its tolerances.

### Result

The locking device passed the test.

### 6.3 Verification of the displacements

#### Standard and date

Standard IEC 60372, clause 10.1

Test dates 17 December 2008

sample no's.	method	force (kgf)	average value
1	Vickers	10	321
2	Vickers	10	310
3	Vickers	10	320
4	Vickers	10	298
5	Vickers	10	306

#### Requirement

Average value  $\geq$  150.

#### Result

The locking device passed the test.

## 6.4 Verification of resistance to bending

### Standard and date

Standard IEC 60372, clause 10.2

Test dates 15 January 2009

sample no's.	radius (mm)	splits or cracks
1	3	no
2	3	no
3	3	no
4	3	no
5	3	no

### Requirement

After bending no splits or cracks shall appear.

### Result

The locking device passed the test.

## APPENDIX A MEASUREMENT UNCERTAINTIES

The measurement uncertainties in the results presented are as specified below unless otherwise indicated.

measurement	measurement uncertainty
dielectric tests and impulse current tests	peak value: $\leq 3\%$ time parameters: $\leq 10\%$
capacitance measurement	0,3%
tan $\delta$ measurement	$\pm 0,5\% \pm 5 \times 10^{-5}$
partial discharge measurement	< 10 pC : 2 pC 10 - 100 pC : 5 pC > 100 pC : 20 %
measurement of impedance	$\leq 1\%$
ac-resistance measurement	
measurement of losses	$\leq 1\%$
measurement of insulation resistance	$\leq 10\%$
measurement of dc resistance	1 $\mu\Omega$ - 5 $\mu\Omega$ : 1% 5 $\mu\Omega$ - 10 $\mu\Omega$ : 0,5% 10 $\mu\Omega$ - 200 $\mu\Omega$ : 0,2%
radio interference test	2 dB
calibration of current transformers	$2,2 \times 10^{-4}$ Ii/Iu and 290 $\mu\text{rad}$
calibration of voltage transformers	$1,6 \times 10^{-4}$ Ui/Uu en 510 $\mu\text{rad}$
measurement of conductivity	5%
measurement of temperature	-50 °C- -40 °C: 3 K -40 °C- 125 °C : 2 K 125 °C - 150 °C : 3 K
tensile test	1%
sound level measurement	type 1 meter as per IEC 651 and ANSI S1.4.1971
measurement of voltage ratio	0,1%



## APPENDIX B MANUFACTURER'S DRAWING/DATA SHEET

1 page

drawing no.	description/title	date	rev.
-	insulator 52-5	approved 10/01/2008	-

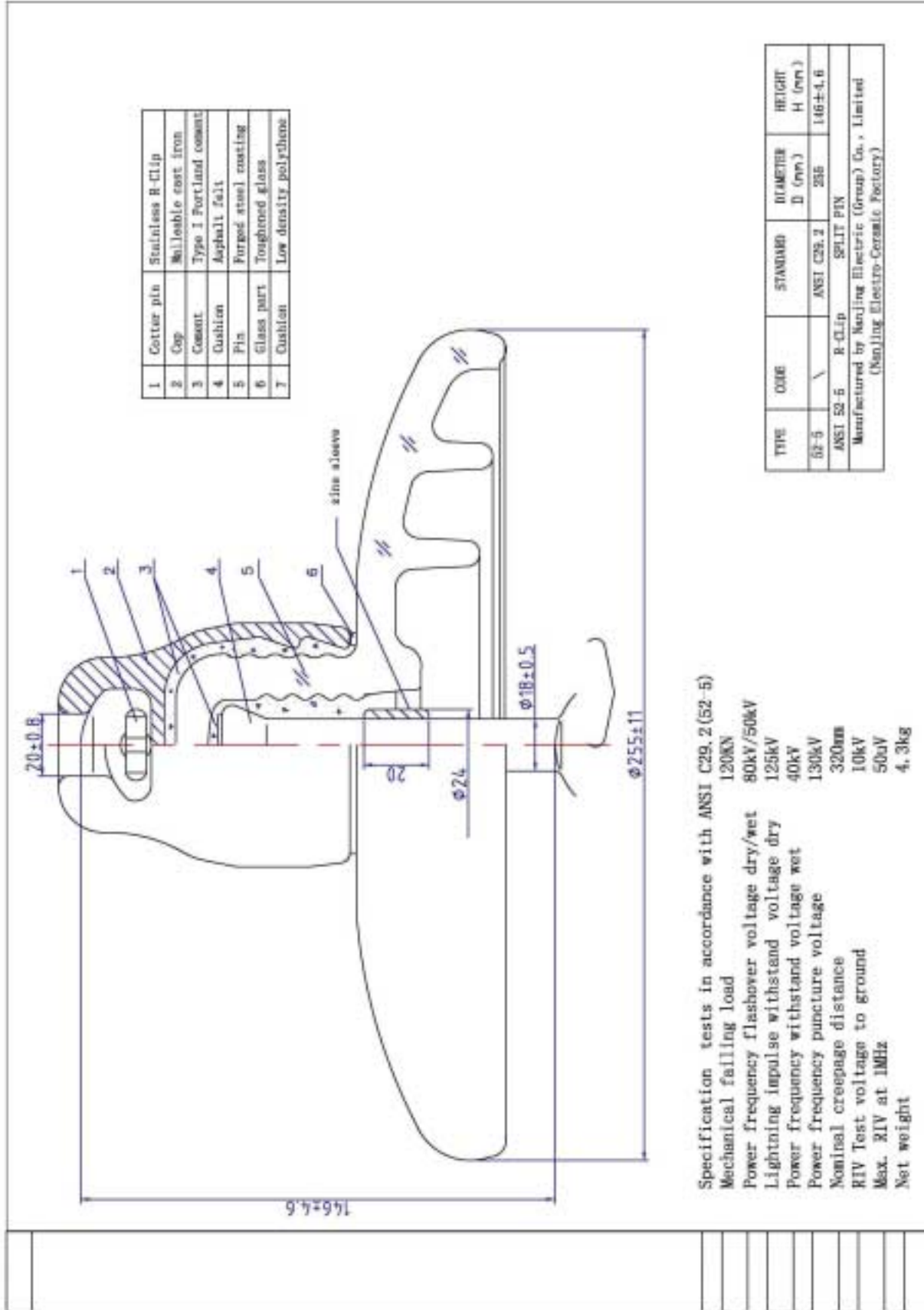

Specification tests in accordance with ANSI C29.2 (52-5)

- Mechanical falling load 120KN
- Power frequency flashover voltage dry/wet 80kV/50kV
- Lightning impulse withstand voltage dry 125kV
- Power frequency withstand voltage wet 40kV
- Power frequency puncture voltage 130kV
- Nominal creepage distance 320mm
- RIV Test voltage to ground 10kV
- Max. RIV at 1MHz 50kV
- Net weight 4.3kg

TYPE	CODE	STANDARD	DIAMETER D (mm)	HEIGHT H (mm)
52-5	\	ANSI C29.2	25.5	146±4.6
ANSI 52-5 R-Clip SPLIT PIN				
Manufactured by Nanjing Electric (Group) Co., Limited (Nanjing Electro-Ceramic Factory)				